

BIM Server: Save/2012 - BIM Server (18/07/14017 Concordia Baton Rouge) Ver: 18.0011 Wednesday, September 02, 2015 1:04 PM

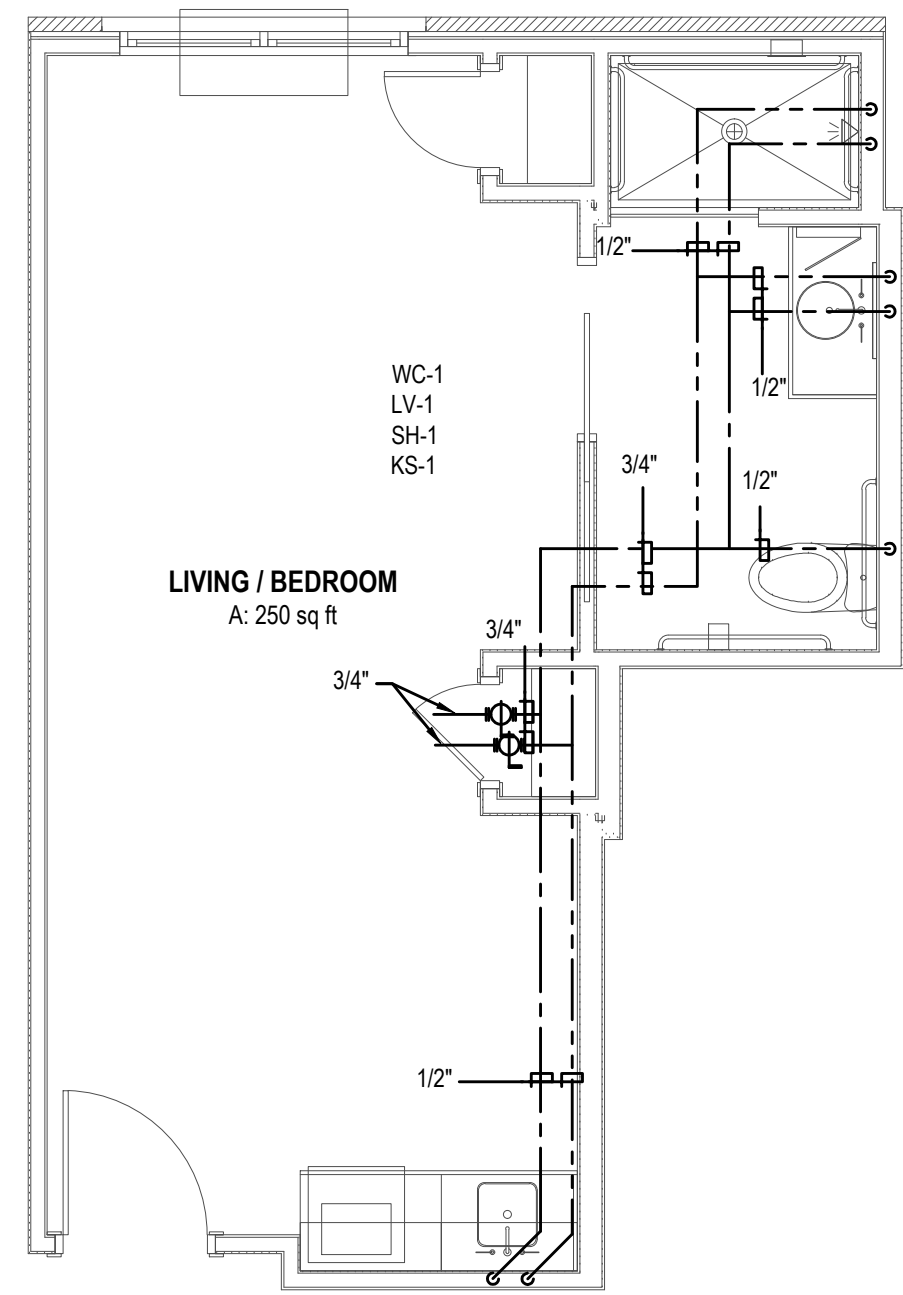

1 | TYPICAL MC UNIT A1.1
P4.1 1/4" = 1'-0"

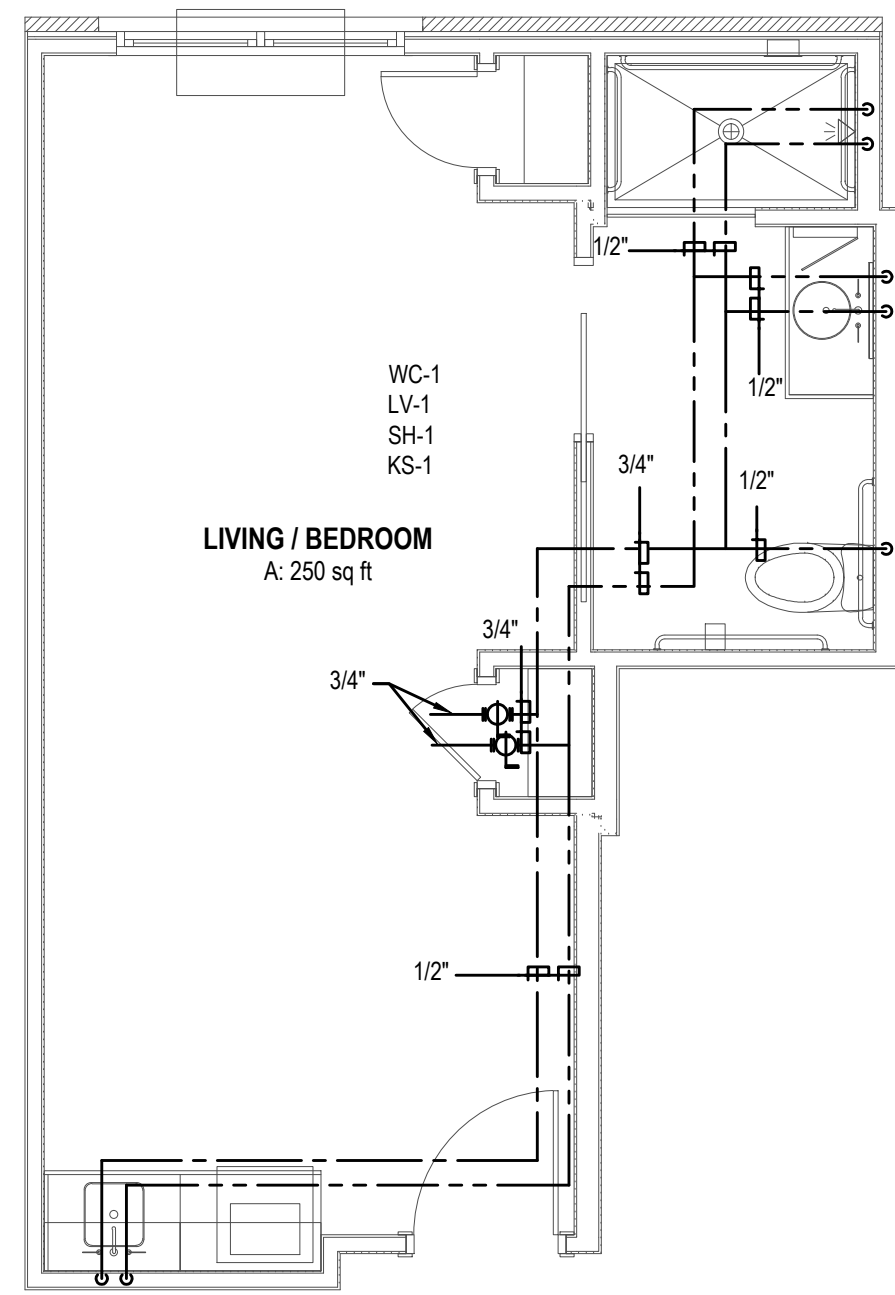

2 | TYPICAL MC UNIT A1.2
P4.1 1/4" = 1'-0"

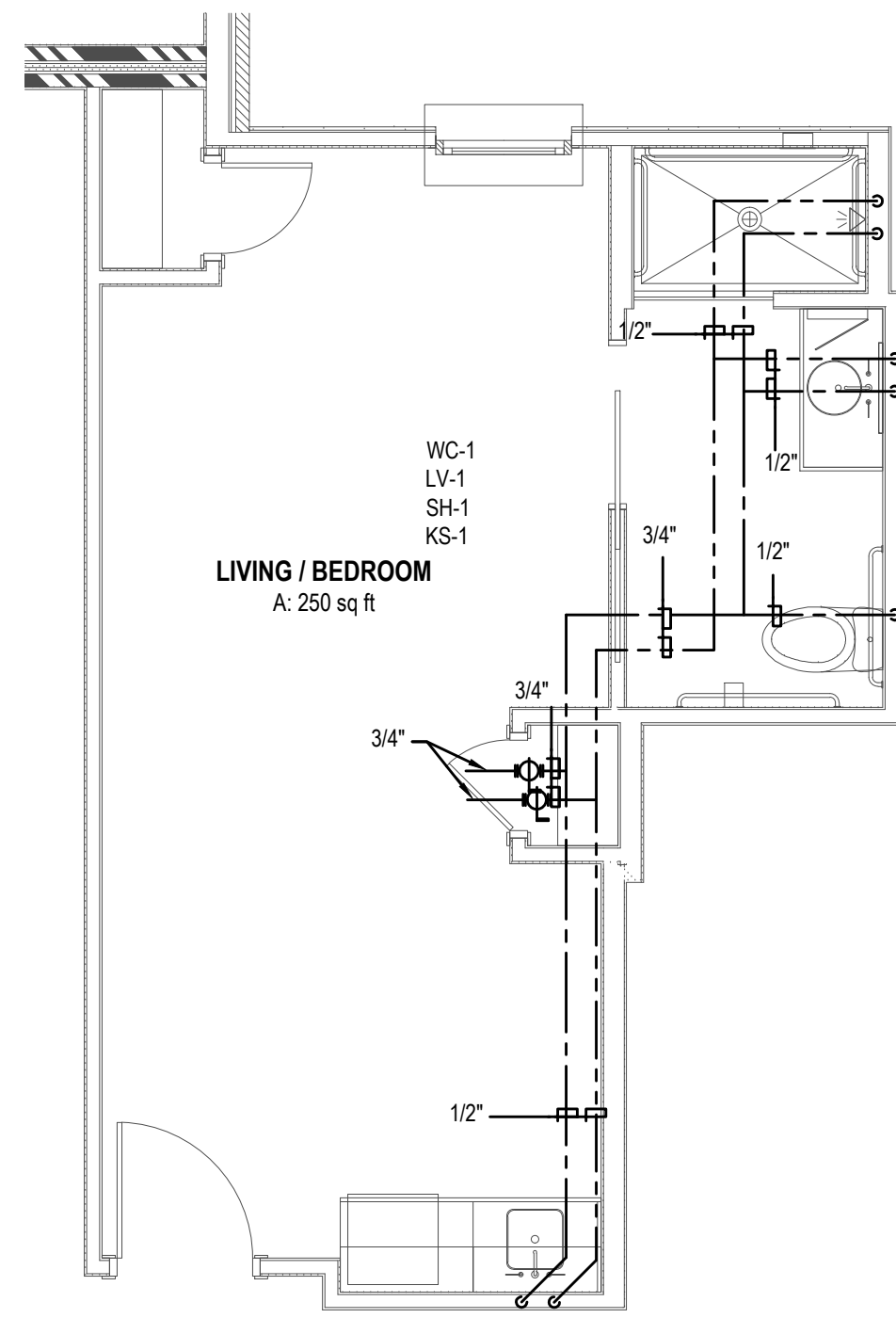

3 | TYPICAL MC UNIT A1.3
P4.1 1/4" = 1'-0"

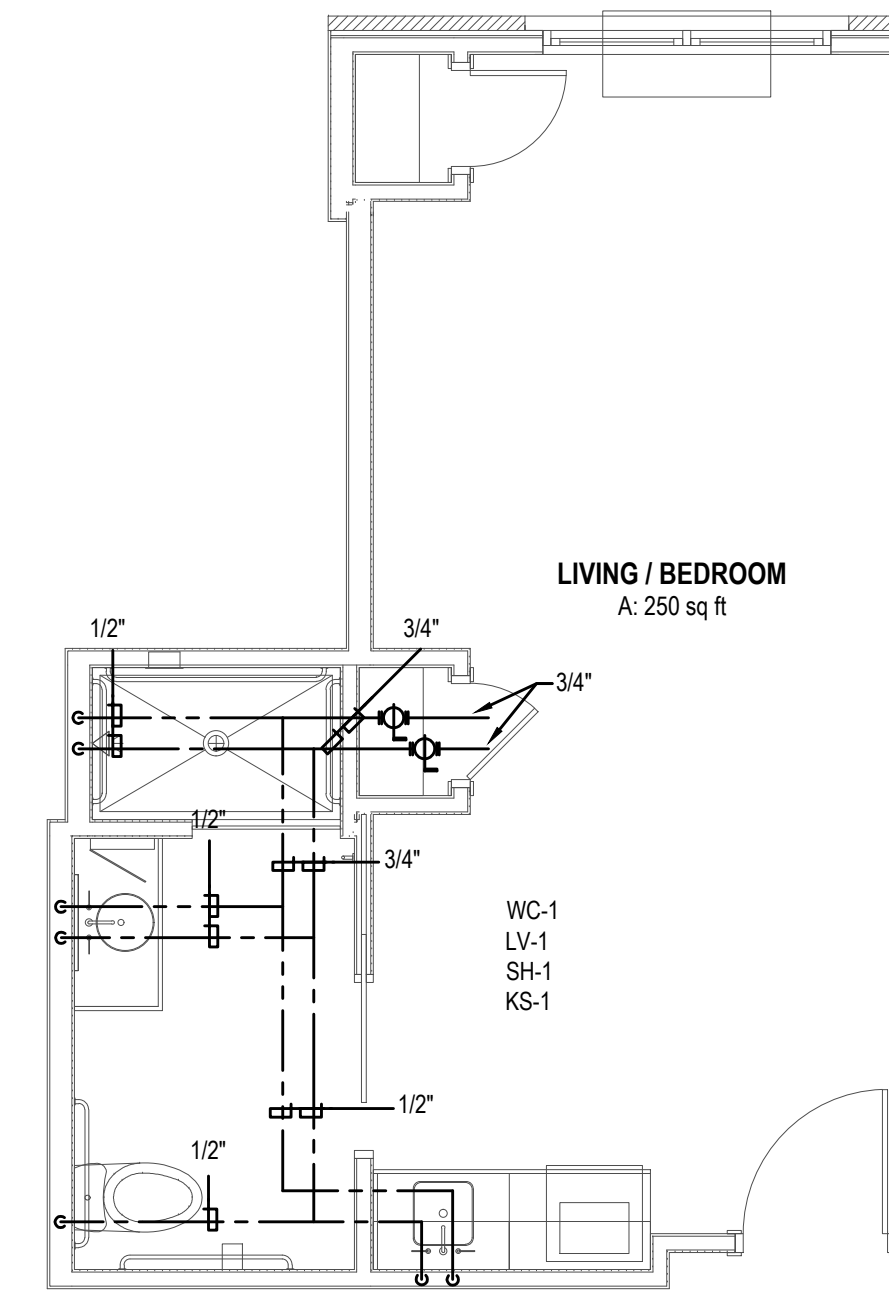

4 | TYPICAL MC UNIT A2.1
P4.1 1/4" = 1'-0"

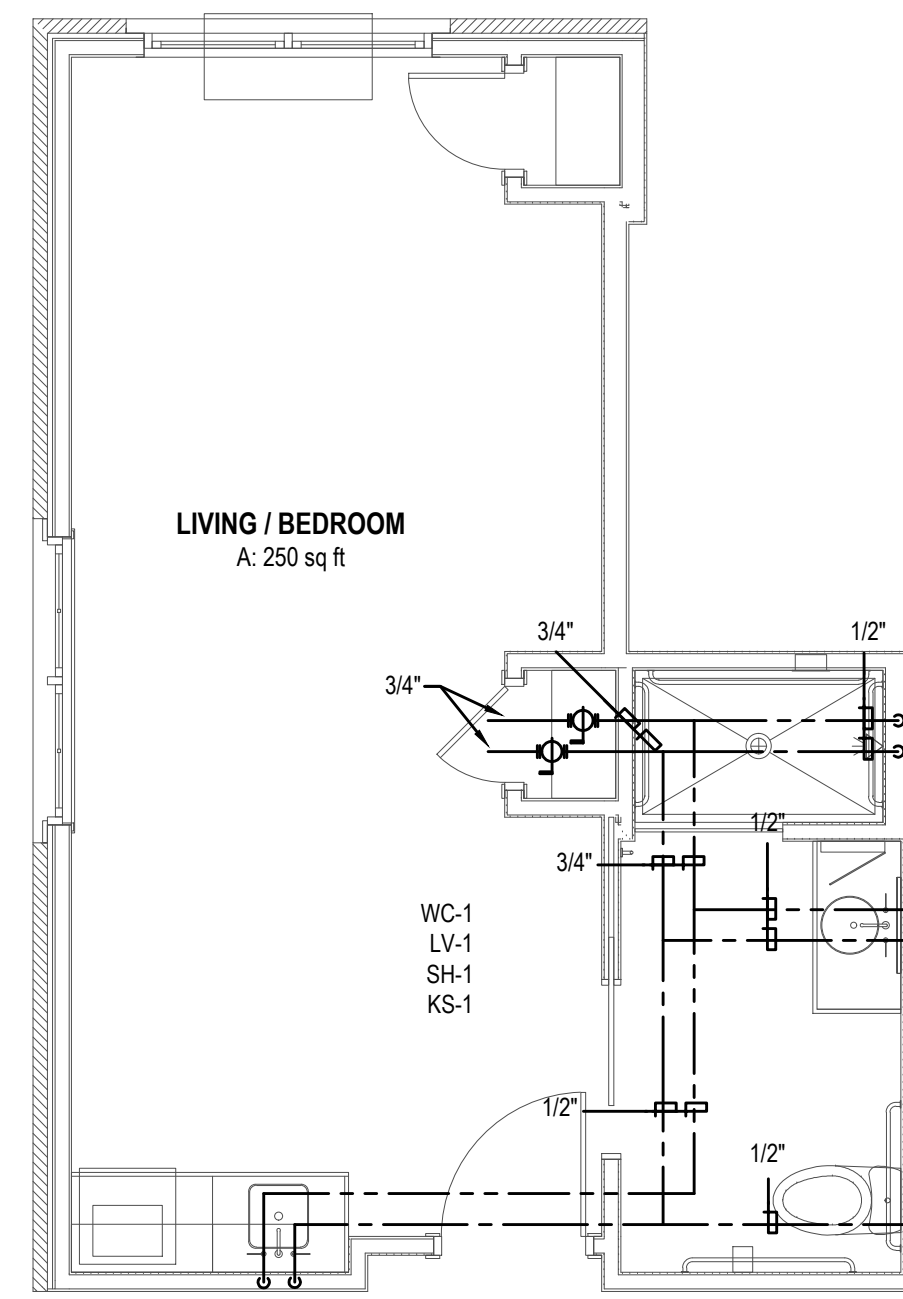

5 | TYPICAL MC UNIT A2.2
P4.1 1/4" = 1'-0"

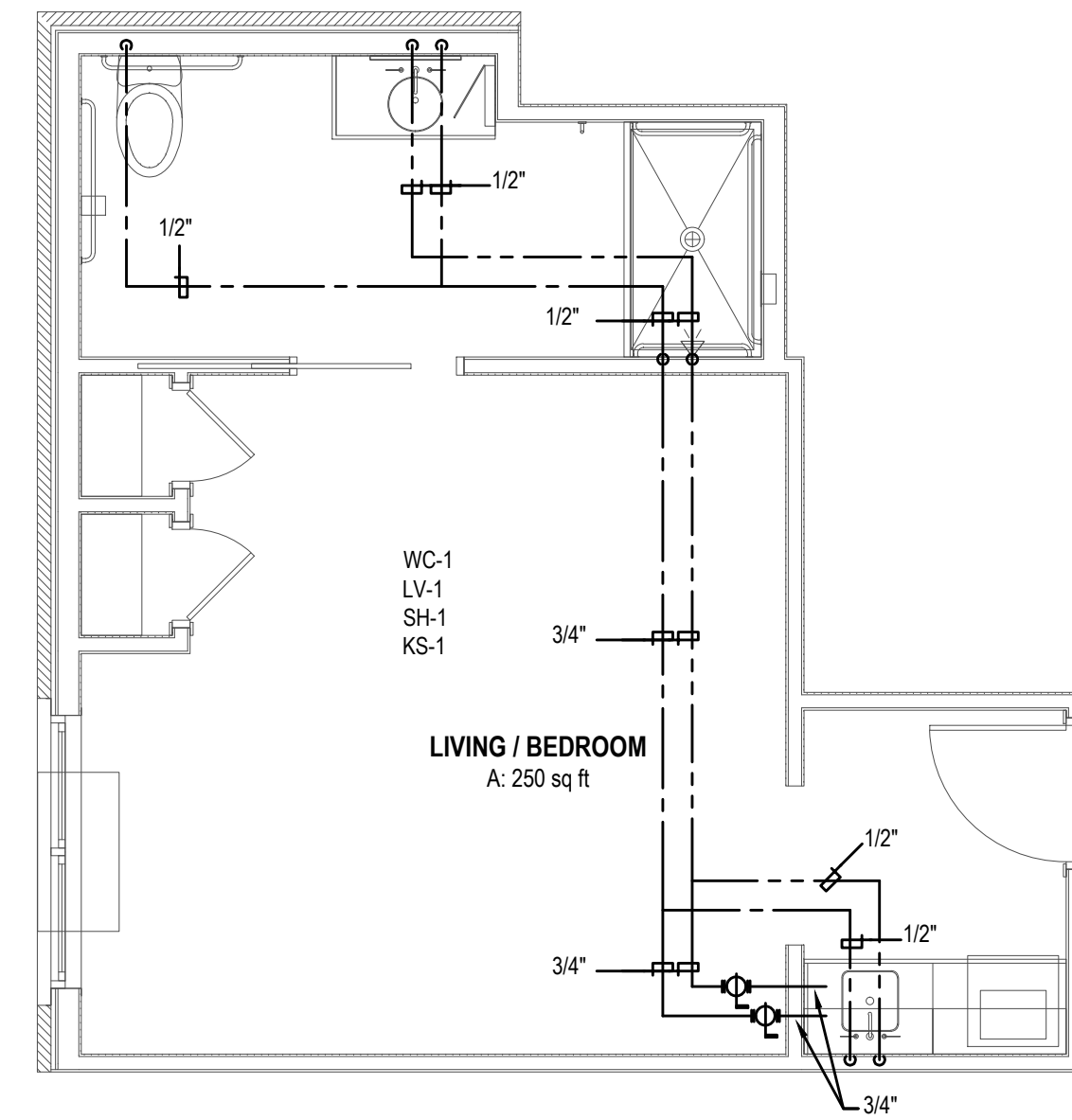

6 | TYPICAL MC UNIT A3
P4.1 1/4" = 1'-0"

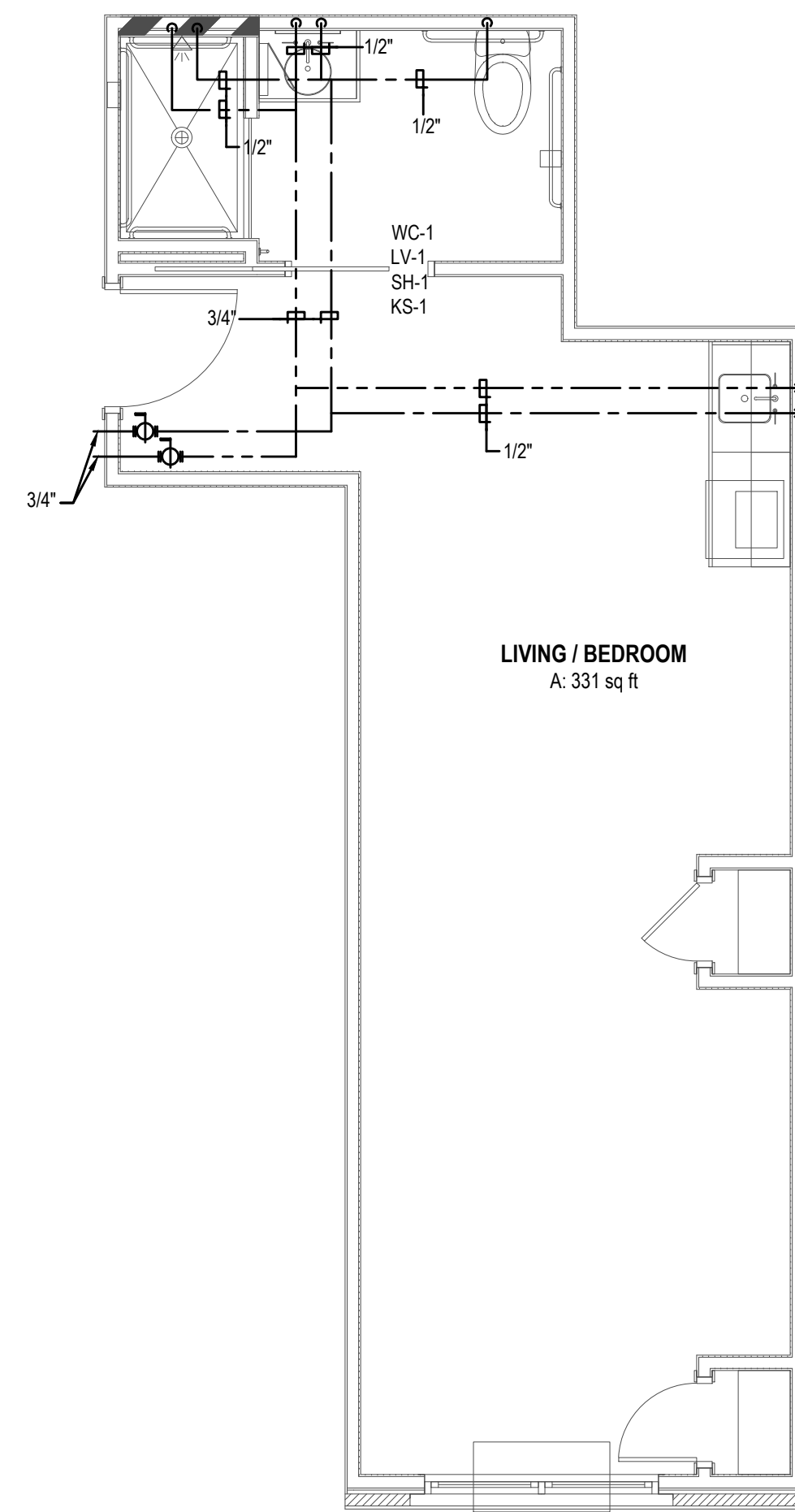

7 | TYPICAL MC UNIT A4
P4.1 1/4" = 1'-0"

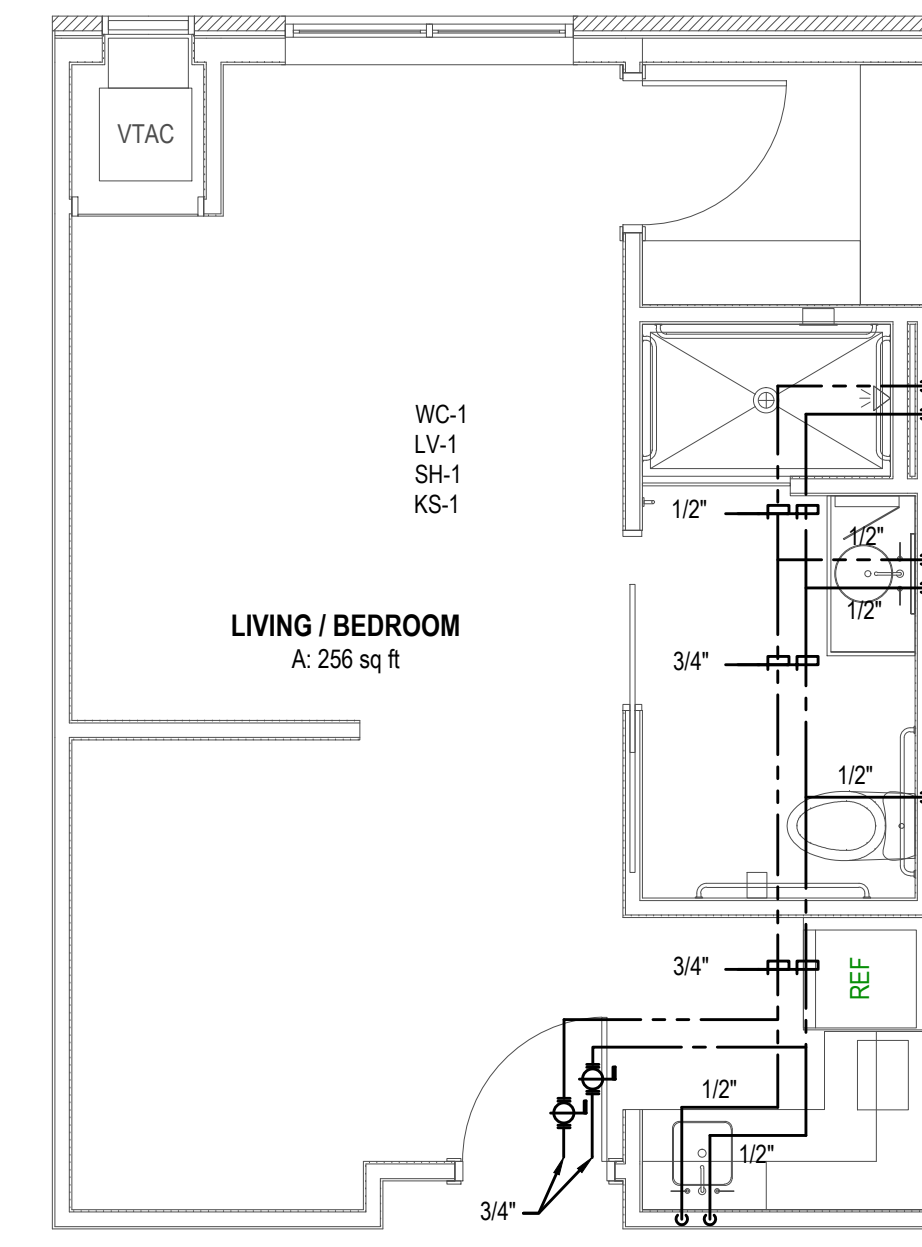

8 | TYPICAL AL UNIT A1.1
P4.1 1/4" = 1'-0"

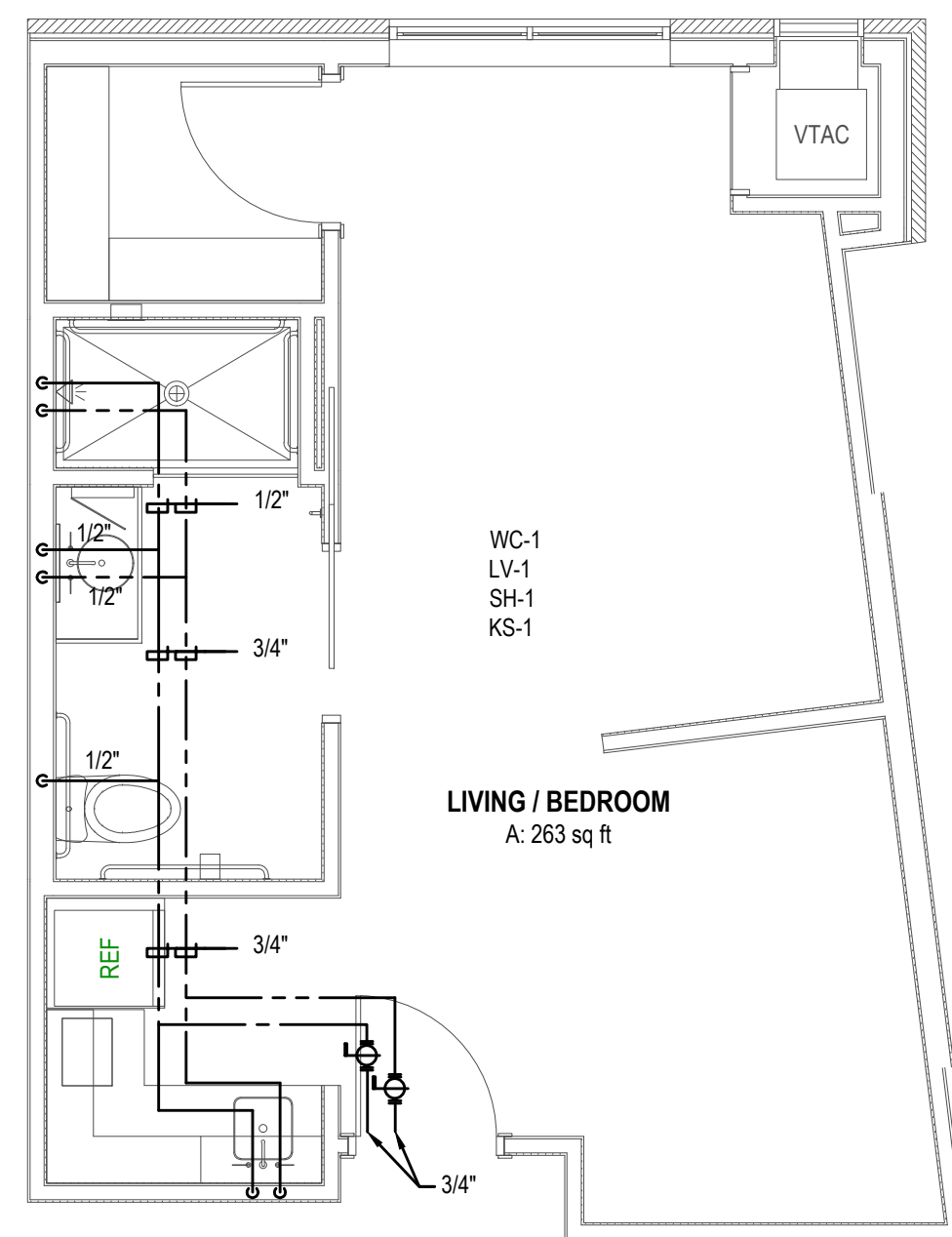

9 | TYPICAL AL UNIT A1.2
P4.1 1/4" = 1'-0"

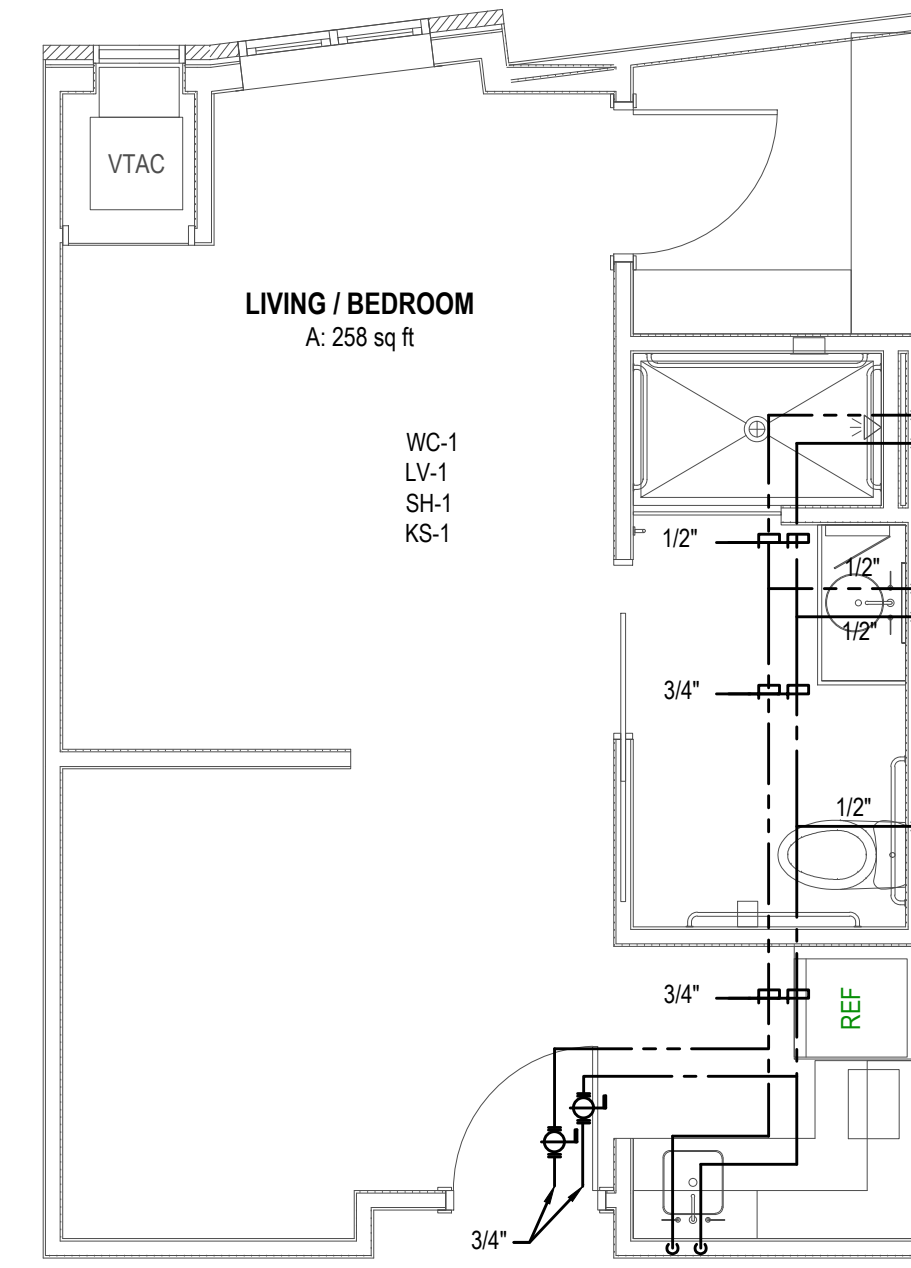

10 | TYPICAL AL UNIT A1.3
P4.1 1/4" = 1'-0"

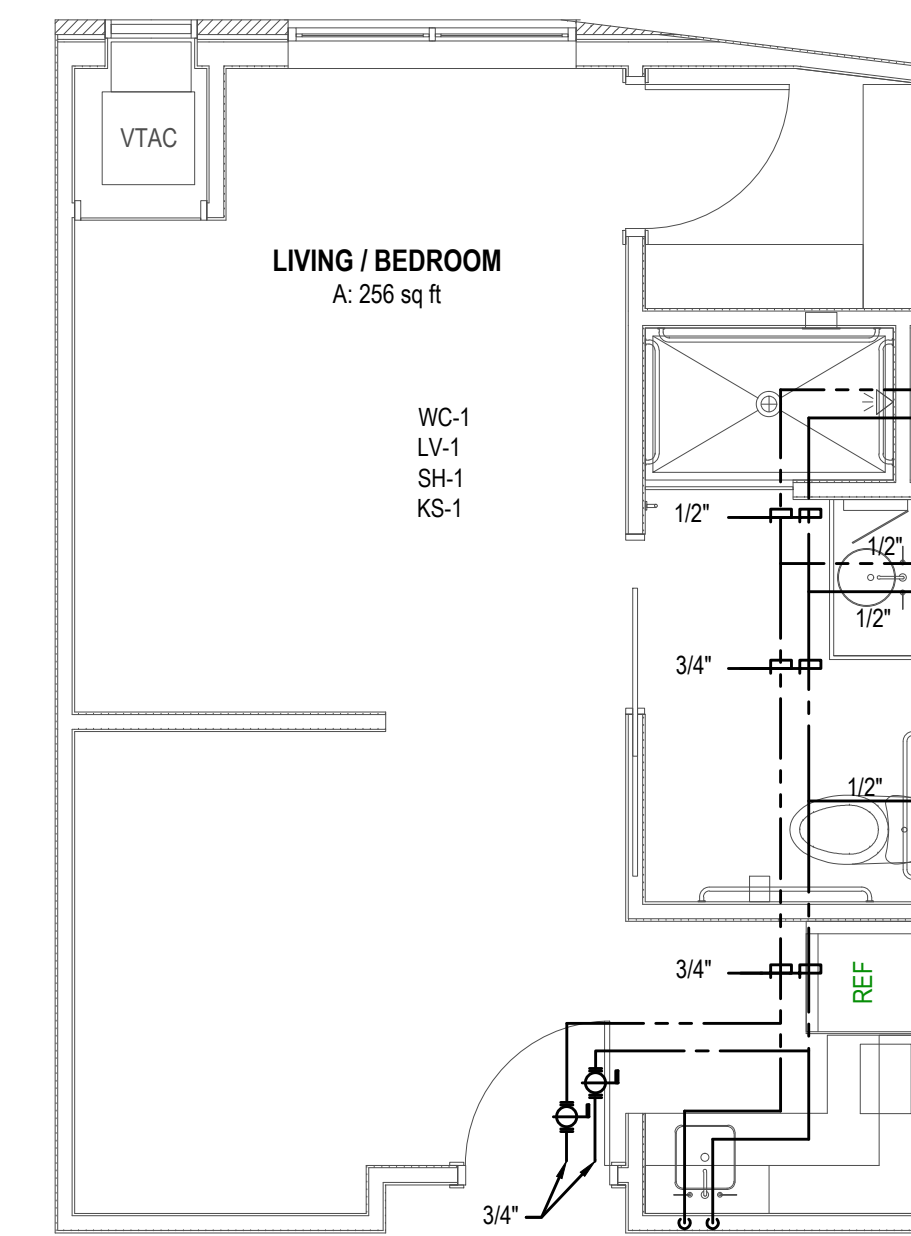

11 | TYPICAL AL UNIT A1.4
P4.1 1/4" = 1'-0"

CONTRACTOR NOTE
IT IS THE RESPONSIBILITY OF THE CONTRACTOR TO NOTIFY THE ARCHITECT, LANDLORD AND TENANT OF ANY DISCREPANCIES ENCOUNTERED ON THE PLANS OR IN EXISTING SITE CONDITIONS PRIOR TO SUBMISSION OF BID.
BIDDERS ARE TO VISIT THE SITE AND FAMILIARIZE THEMSELVES WITH EXISTING CONDITIONS AND SATISFY THEMSELVES AS TO THE NATURE AND SCOPE OF THE WORK. THE BASE BID SHALL REFLECT MODIFICATIONS TO SYSTEMS AND DEVICES AS REQUIRED BY STATE, LOCAL AND FEDERAL CODES WHETHER INDICATED OR NOT ON CONTRACT DOCUMENTS. THE SUBMISSIONS OF A BID WILL BE EVIDENCE THAT SUCH AN EXAMINATION AND COMPLIANCE WITH GOVERNING CODES/REQUIREMENTS HAS BEEN MADE. LATER CLAIMS FOR LABOR, EQUIPMENT, OR MATERIALS REQUIRED, OR FOR DIFFICULTIES ENCOUNTERED WHICH COULD HAVE BEEN FORESEEN HAD AN EXAMINATION AND CODE/REQUIREMENTS REVIEW BEEN MADE, WILL NOT BE ALLOWED.