

BIM Server: Server2012 - BIM Server (18/07/14)17 Concordia Baton Rouge | Ver: 18.001 | Wednesday, September 02, 2015 | 4:04 PM

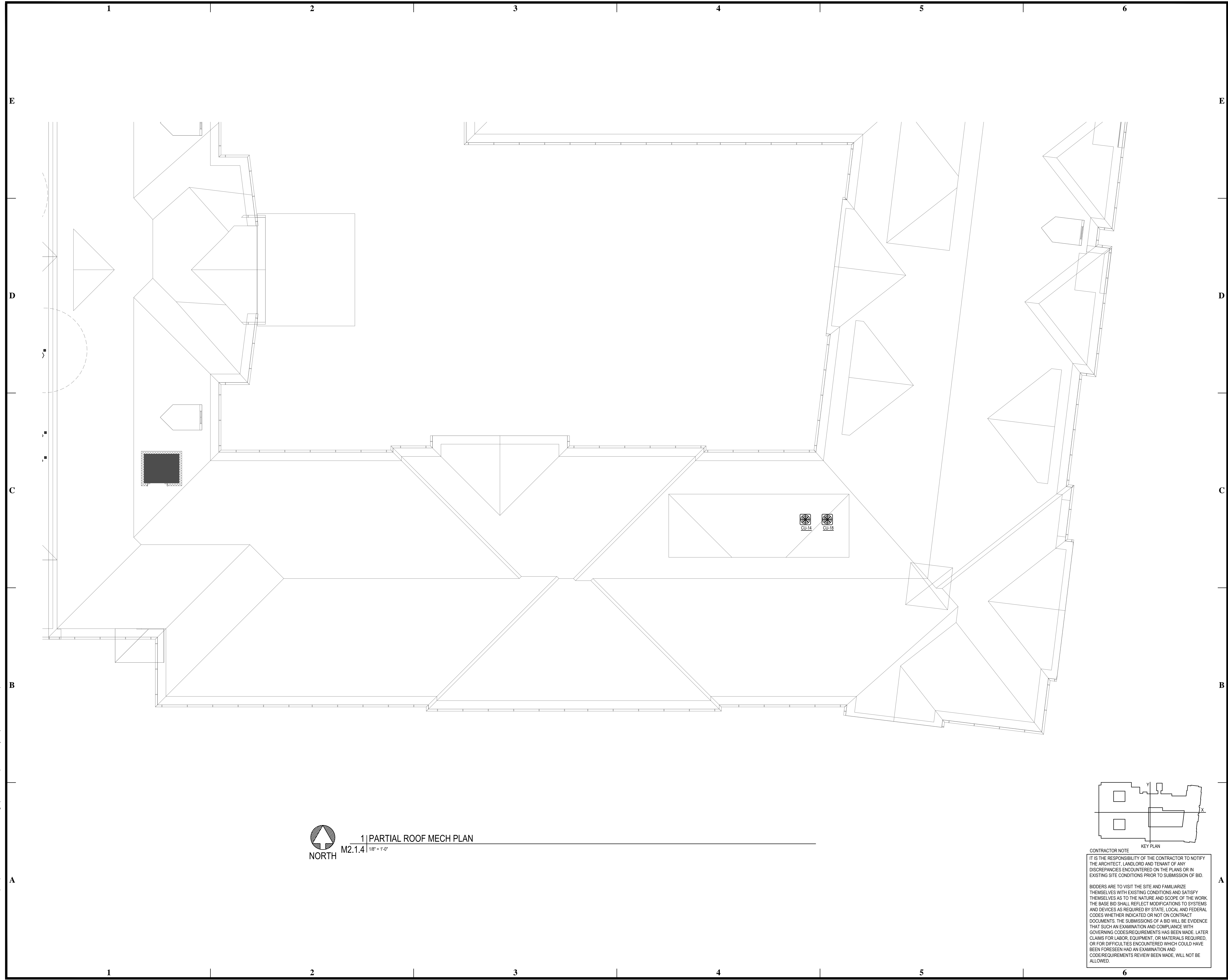

1 | PARTIAL ROOF MECH PLAN  
M2.1.4 | 1/8" = 1'-0"

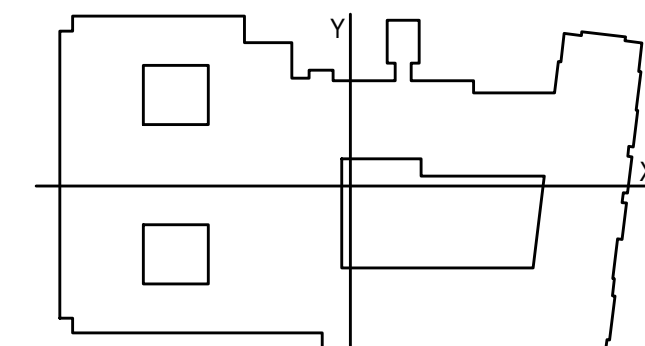

CONTRACTOR NOTE  
IT IS THE RESPONSIBILITY OF THE CONTRACTOR TO NOTIFY THE ARCHITECT, LANDLORD AND TENANT OF ANY DISCREPANCIES ENCOUNTERED ON THE PLANS OR IN EXISTING SITE CONDITIONS PRIOR TO SUBMISSION OF BID.  
BIDDERS ARE TO VISIT THE SITE AND FAMILIARIZE THEMSELVES WITH EXISTING CONDITIONS AND SATISFY THEMSELVES AS TO THE NATURE AND SCOPE OF THE WORK. THE BASE BID SHALL REFLECT MODIFICATIONS TO SYSTEMS AND DEVICES AS REQUIRED BY STATE, LOCAL AND FEDERAL CODES WHETHER INDICATED OR NOT ON CONTRACT DOCUMENTS. THE SUBMISSIONS OF A BID WILL BE EVIDENCE THAT SUCH AN EXAMINATION AND COMPLIANCE WITH GOVERNING CODES/REQUIREMENTS HAS BEEN MADE. LATER CLAIMS FOR LABOR, EQUIPMENT, OR MATERIALS REQUIRED, OR FOR DIFFICULTIES ENCOUNTERED WHICH COULD HAVE BEEN FORESEEN HAD AN EXAMINATION AND CODE/REQUIREMENTS REVIEW BEEN MADE, WILL NOT BE ALLOWED.

**pi architects**  
3500 Jefferson St. Suite 303  
Austin, TX 78731  
P: (512) 231-1910  
F: (512) 231-1950  
www.piarch.com  
architecture + master  
interior + landscape  
architecture  
**PE Services**  
www.pe-services.com

These plans have been properly examined by the undersigned. I have determined that they comply with existing local Louisiana codes, and have been properly site adapted to use in this area.

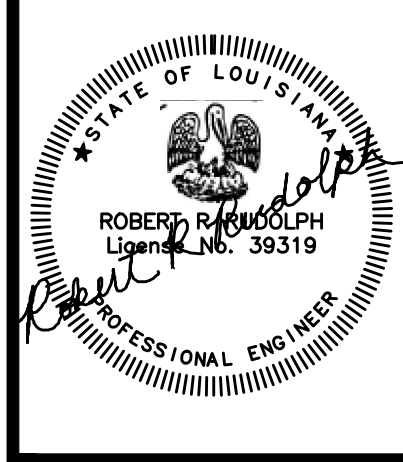

**WATERSTONE AT BATON ROUGE  
ASSISTED LIVING & MEMORY CARE**  
SIEGEN LANE  
BATON ROUGE, LA 70810

ISSUE: PERMIT SET

©2015 PI ARCHITECTS, INC.  
REVISIONS:

DATE: 03/31/2016  
PROJECT NUMBER: PES 15090  
SHEET TITLE:  
**PARTIAL ROOF MECH PLAN**

SHEET:  
**M2.1.4**